

## Process Analysis Systems

Chem

Energy

Pharm

Food

Water

### Protos® 3400 (X)

The modular measuring system for pH, conductivity and oxygen, for application in hazardous and safe areas.



**This device will help you make considerable savings.**

The perfectly designed Protos® 3400 (X) measuring system is based on a modular hardware and software concept for liquid analysis and offers flexible solutions precisely tailored to the measuring task. It is also possible to easily measure several process variables such as pH/Cond, pH/pH, Cond/Oxy etc. with the appropriate configuration. The device is fitted with 3 slots and, similar to a PC, it can be simply retrofitted or modified at any time.

With all these advantages, the Protos® 3400 (X) offers a previously unknown level of functionality and reliability, and with an extraordinarily high level of user comfort.

A razor-sharp display guarantees superb legibility in the most diverse of light conditions. The integrated SMARTMEDIA card allows for the trouble-free saving of configurations, software updates, and measurement data.

The hygienic stainless steel enclosure is ideal for applications in:

- biotechnology
- the pharmaceutical industry
- the food industry

The sturdy, corrosion-resistant, coated steel enclosure stands up well to harsh industrial environments.

For applications in:

- the chemical industry
- the paper industry
- power station engineering
- water/wastewater technology

The Protos® 3400 (X) can easily be integrated into PROFIBUS PA or FOUNDATION Fieldbus networks. The measuring system also supports all common analog and digital sensors.

### Warranty 3 years!

#### Warranty

Defects occurring within 3 years from delivery date shall be remedied free of charge at our plant (carriage and insurance paid by sender).  
Sensors and accessories: 1 year



## Facts

- Protos® 3400 (X) S: tightly sealed stainless steel enclosure with hygienic design
- Protos® 3400 (X) C: sturdy, corrosion-resistant coated steel enclosure
- plain-text user interface according to NAMUR – simple and intuitive
- great flexibility provided by modular technology
- modular hardware and software concept permits retrofitting at any time
- 5 process variables simultaneously
- SMARTMEDIA card for saving and transmission of parameter settings, software updates, and measuring data
- high-resolution, transreflective display, white backlighting
- perfect legibility in all light conditions
- operator guidance icon-led
- 6 languages as standard
- global usability thanks to VariPower® power supply, 20 ... 265 V AC/DC
- measuring circuits, galvanically isolated
- 2 current outputs and 4 relay contacts in the basic model
- 2-channel measurement recorder, time and event-controlled, with increased resolution on quick changes
- parameter-set switchover, also remotely
- HOLD function, can be remote-controlled
- KI recorder detects abnormalities in processes
- Sensocheck® sensor monitoring
- connection possibilities for almost all typical analog and digital sensors available in the world
- optional ComFu® wireless set for wireless data transmission
- ServiceScope® – noise level monitoring of the pH input
- sensor network diagram – synchroptic representation of the sensor data
- sensor wear monitor
- sensor load matrix
- adaptive calibration timer – automatic standardization
- lightning protection
- explosion protection: II 2(1) GD Ex me ib [ia] IIC T4 T 70 °C
- control of the fully automatic Unical® 9000 (X) calibration system
- control of the fully automatic Unclean® 900 (X) cleaning system
- PROFIBUS PA
- FOUNDATION Fieldbus
- 3-year warranty



# Process Analysis Systems

Chem

Energy

Pharm

Food

Water

## Protos® 3400 (X)

### SMARTMEDIA



#### Everything on one card

The SMARTMEDIA card, measuring only 4.5 by 3.7 cm and being 1 mm thick, is an extremely compact memory expansion medium available for the Protos® system.

The SMARTMEDIA card can be connected via the very inexpensive, generally available adapter to RS 232 C, USB etc. or directly via a PCMCIA adapter to any PC.

#### For software updates and software functions

- contains the complete Protos® software
- software functions can be installed at a later date and activated via transaction numbers (TAN)
- software updates to keep Protos® upgraded with the latest software – even on site

#### For parameters and the recording of data

- 5 parameter sets can be filed and loaded into the device
- A parameter set contains all parameter data, facilitating rapid exchange and speedy complete parameter setting. Simple return to factory settings

- almost unlimited expansion of the measurement recorder
- Parameter sets can be transmitted from one device to another. This removes the need for the tiresome repetition of inputting parameters.
- The device parameters can be completely saved on a SMARTMEDIA card and then archived directly or on a PC
- extended logbook
- "Electronic Records" and "Electronic Signatures" according to directive FDA 21 CFR, Part 11

SMARTMEDIA is a registered trademark of Toshiba Corp., Japan



Simple operation: Simply insert the SMARTMEDIA card into the small slot on the rear of the front door.

**The Functions**

**Progress in perfection**

Alongside outstanding features like the universal VariPower® power supply 20 ... 265 V / AC/DC, the time- and event-controlled 2-channel measurement recorder, and Sensocheck® sensor monitoring, the Protos® 3400 system shines with further pioneering functions:

**Early alarm detection with the KI recorder**

The KI recorder follows the course of the process and releases a messages in the event of a deviation. The monitoring is always carried out for the primary measured variable, e.g. pH or conductivity and at the same time the temperature. The visualization is graphical with process and limit value variation for both variables.

**Checking batch processes with the KI recorder**

The KI recorder records the course of a batch (self-teaching function). All further batches are then monitored for deviations from the saved course.

**Sensor network diagram for pH measurement**

Graphical representation of current sensor parameters in a network diagram on the display – with slope, zero, reference impedance, glass impedance, response time, calibration timer, sensor wear.

**ServiceScope®**

This function monitors the pH input signal and checks whether it remains in the control range. Moreover, the representation of the noise level over time allows the distinction to be made between individual disturbances, periodic and broad-band disturbances, which is helpful for troubleshooting. In this way, it is possible to simply detect regularly recurring disturbances, e.g. large consumers which are regularly switched on or off. An error message is generated if the noise level exceeds the failure limit.

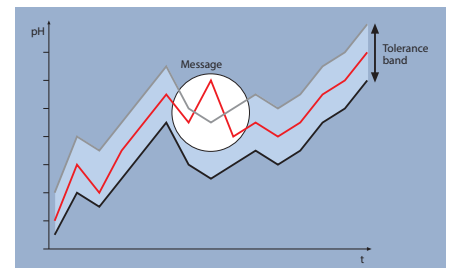

KI recorder

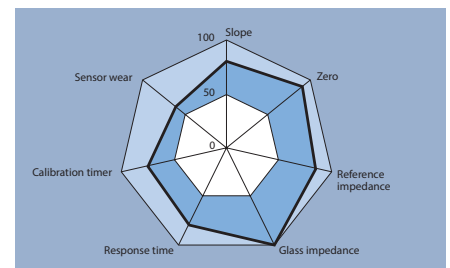

Sensor network diagram

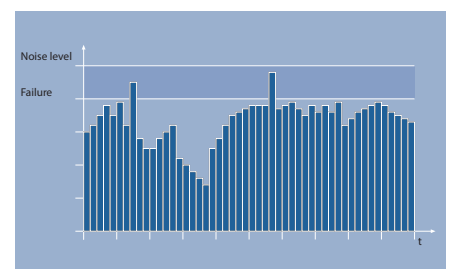

ServiceScope®



# Process Analysis Systems

Chem

Energy

Pharm

Food

Water

## Protos® 3400 (X)

### Modules

#### Universally interchangeable

Various user-defined plug-in measuring modules for measurement and control functions can be combined depending on the measuring task. They also facilitate subsequent trouble-free expansion or modification.

Communication modules for functional expansion: In addition to the OUT module for the expansion of the output options already available as standard, other modules are also available, including modules for PROFIBUS and FOUNDATION Fieldbus.

Combined with the PHU or FIU measuring and control module, Unical® 9000 (X) / Uniclean® 900 (X), and a retractable probe such as Ceramat® WA 150 or SensoGate® WA 130, the Protos® 3400 (X) becomes a fully automatic remote-controlled calibration and cleaning system.

If necessary, it can also record several measurement parameters in any combination with a one device; pH/pH, Cond/Cond etc. and it allows simultaneous pH and conductivity measurement with analog or digital sensors such as Memosens®.



Combined evaluation – i.e. the calculation of several measuring parameters e.g. for differential measurement or quasi-redundant measuring systems. Up to 3 measuring modules can be combined.

Plug & Play – the modules are simply clicked into place in the slots provided, in any order; the modules are automatically recognized; very straightforward retrofitting or modification; hot-swap technology.

Control module for convenient PID control. Analog and digital outputs as well as limit monitoring.

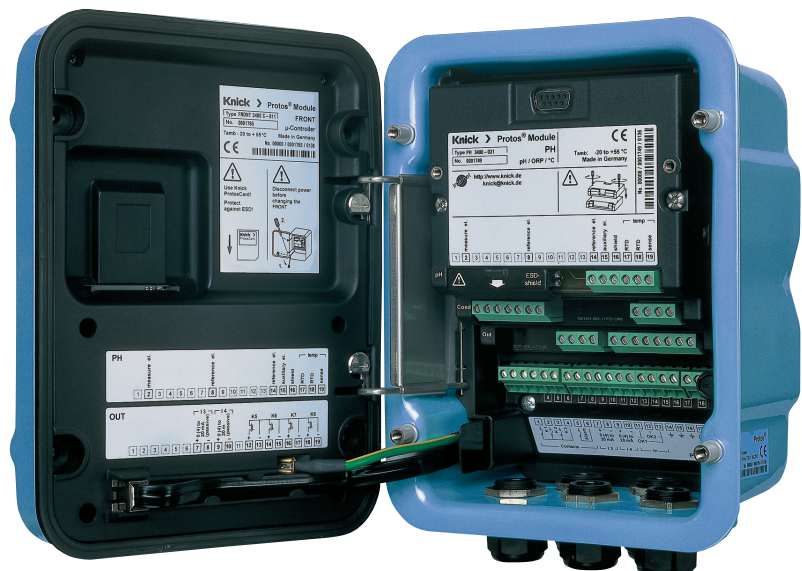
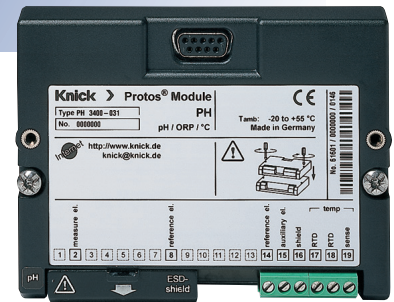

## Modules – continued

### PH measuring modules

Input module for pH measurement with glass electrodes, ISFET and enamel sensors.

Simultaneous measurement of pH value, ORP, and temperature, also with ISM sensors (Intelligent Sensor Management) and Memosens® sensors.

- Sensocheck® monitoring of glass and reference electrode
- sensor monitor
- sensor wear monitor
- sensor load matrix
- sensor network diagram
- ServiceScope® noise level monitoring of the pH input
- adaptive calibration timer
- timer for sensor checking
- Calimatic® automatic calibration
- KI recorder

### COND measuring module

Input module for measuring conductivity with 2- or 4-electrode sensors. Simultaneous measurement of electrical conductivity, resistivity, concentration, salinity, and temperature.

- large measuring range with 2-electrode sensors due to special measuring process
- Sensocheck® polarization detection and monitoring of cable capacitance
- sensor monitor
- USB ultrapure-water monitoring in the pharmaceutical industry

### CONDI measuring module

Input module for conductivity measurement with commercial electrodeless sensors.

Simultaneous measurement of electrical conductivity, resistivity, concentration, salinity, and temperature.

- Sensocheck® sensor monitoring
- sensor monitor
- Universal application with many commercial electrodeless conductivity sensors. Adaptation via sensor ID

### OXY measuring modules

Input module for measuring oxygen in liquids. Simultaneous measurement of oxygen partial pressure, barometric pressure, and temperature, also with ISM sensors (Intelligent Sensor Management). Calculation of oxygen saturation and concentration. For standard applications and trace measurements in both aqueous media and gases.

- Sensocheck® sensor monitoring – monitoring of the membrane and electrolyte
- sensor monitor
- sensor wear monitor
- sensor load matrix
- automatic correction of barometric pressure influence
- also suitable for trace-oxygen measurement in the ppb range
- external pressure correction

### PHU measurement and control module

Activation of the fully automatic Unical® 9000 (X) / Uniclean® 900 (X) measurement, cleaning, and calibration system.

- integrated pH measurement input
- manual, interval- and time-controlled start of calibration and rinsing programs
- 8 programs available

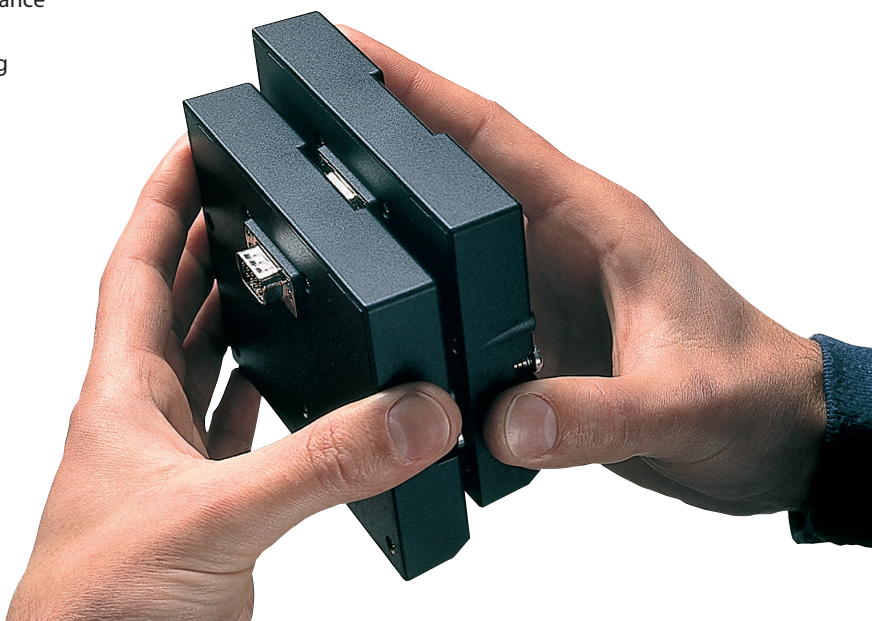

# Process Analysis Systems

Chem

Energy

Pharm

Food

Water

## Protos® 3400 (X)

### Communication Modules

#### OUT communication module

General output module for the expansion of outputs available as standard.

- 4 freely definable electronic relay outputs
- 2 additional passive analog outputs for further process variables

#### PROFIBUS COMPA communication module

PROFIBUS PA communication unit

- fast, cyclic signal transmission with status
- function block model (PROFIBUS Profile 3.0)
- hazardous-area connection according to the FISCO model
- EDD for SIMATIC PDM

#### FOUNDATION Fieldbus communication module

Expansion for bus-capable field device

- fast, cyclic signal transmission with status
- function block model
- hazardous-area connection according to the FISCO model
- EDD for AMS

#### PID controller module

Convenient PID controller.

- continuous controller for the actuation of control valves
- quasi-continuous pulse length/pulse frequency controller for the actuation of straightway valves or metering pumps
- 2 free limit-value contacts, e.g. for three-point control of secondary control processes

#### FIU digital module

Enables connection of intelligent digital Memosens® sensors and Unical® 9000 (X) / Uniclean® 900 (X) for controlling sensor lock-gates. Supports wireless transmission of measurement data (ComFu®).

- 2 Memosens® sensors can be operated simultaneously

#### MS digital module

Connection of a Memosens® sensor. Also with a current input and a relay input, e.g. for monitoring equipment.

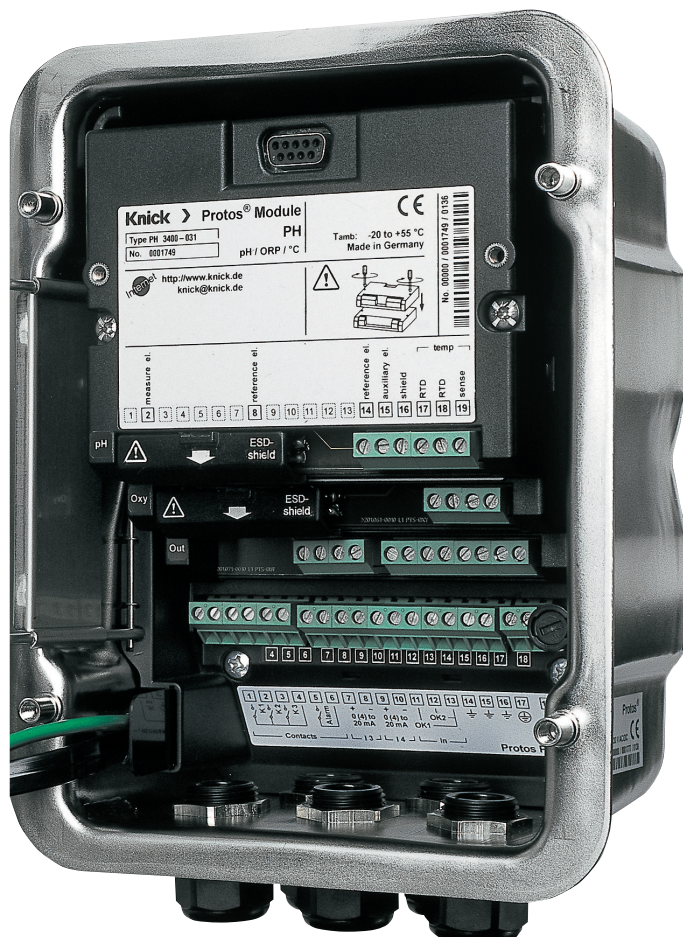

For up-to-date information, please visit [www.knick.de](http://www.knick.de)



## ProgaLog 3000

PC software for offline parameter setting and documentation of Protos® process analysis systems.



ProgaLog 3000, the PC-based tool for simple offline parameter setting of the Protos® process analysis system. The software enables comprehensive parameter setting, even of multi-channel Protos® systems, and beyond this of a complete Unical®/ Uniclean® system. It includes complete program flows for a fully automatic pH measurement system, including a cleaning program and automatic calibration and control of the sensor lock-gate. Despite these complex parameter options, the interface of the ProgaLog software is well-structured and easy to handle.

### Convenient operation

Explorer-style display of the device configuration to keep track of and set up hardware options in self-explanatory fashion.

- graphical user interface for tabular lists of parameters and parameter values
- use of the familiar terms from the Protos® measuring system in the selected language
- program interface in German or English
- entry of Protos® hardware configuration either manually or read from a saved configuration

Value ranges of parameters, their interdependencies and implications of divergent hardware and software versions are observed.

- image display of the individual modules, accurate in every detail down to representation of the terminal assignments.
- intuitive operation
- graphic illustration of complete cleaning and calibration processes of a Unical® system with optional live tracking in a diagram

### Easy parameter setting

The parameters of the Protos® process analysis system set on the PC are transferred simply to the Protos® device with a SMARTMEDIA card.

In this way, „cloning“ – i.e. identical parameter setting for several Protos® systems – is possible with a minimum effort. Conversely, an existing Protos® configuration can naturally be read

into a PC for further editing and documentation with a SMARTMEDIA card. It is possible to save the configuration there as a data record, print it out, or edit it further and later write it back into the Protos® system.

### Complete documentation

Conversion of the complete configuration into Excel or PDF format is done at the press of a button. This makes complete documentation and archiving of the data records very simple; the option to print also allows for archiving in paper form. ProgaLog 3000 runs on all modern Windows operating systems and can be installed and operated simply without administrator rights.

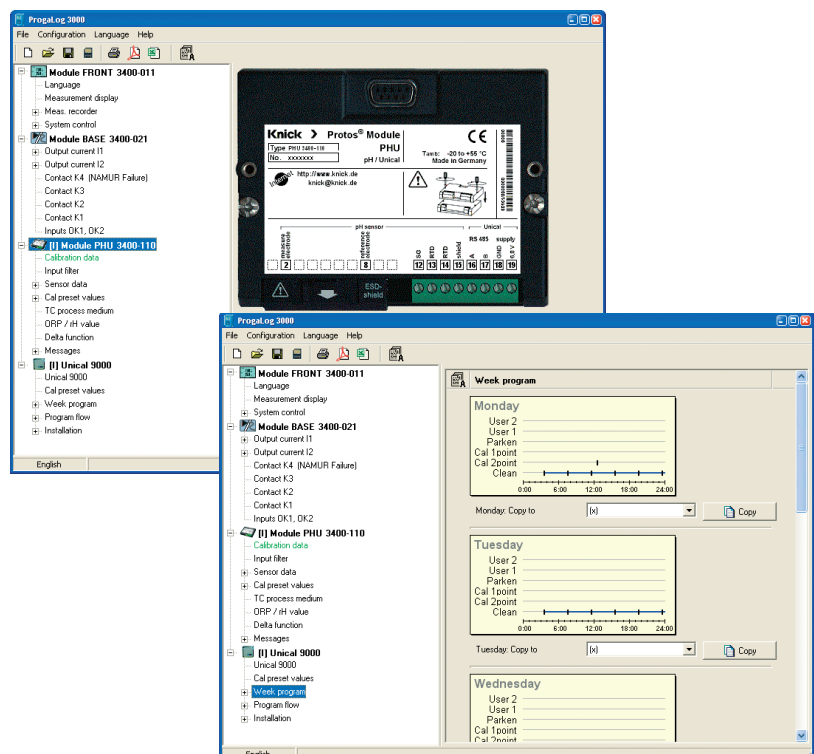



# Process Analysis Systems

Chem

Energy

Pharm

Food

Water

## Protos<sup>®</sup> 3400 (X)

### System Overview

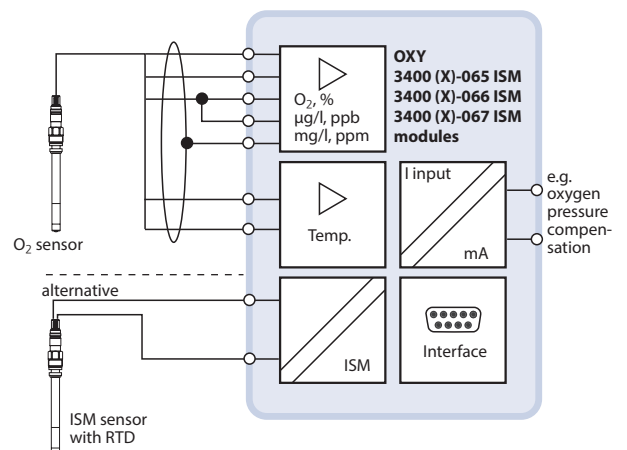
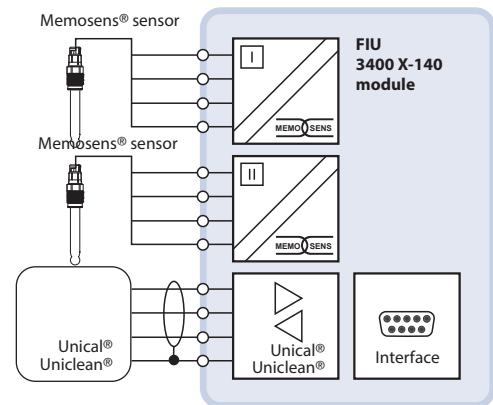
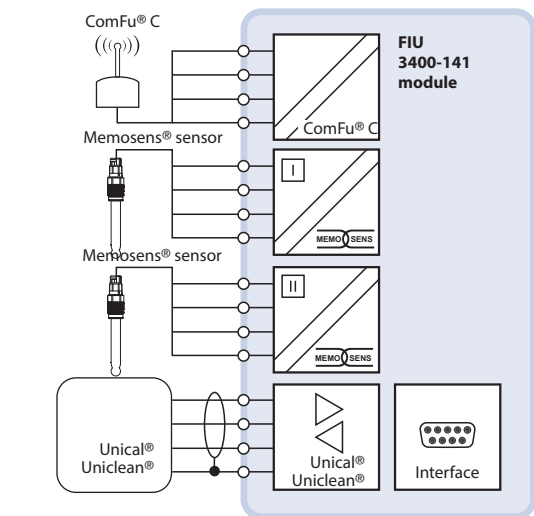
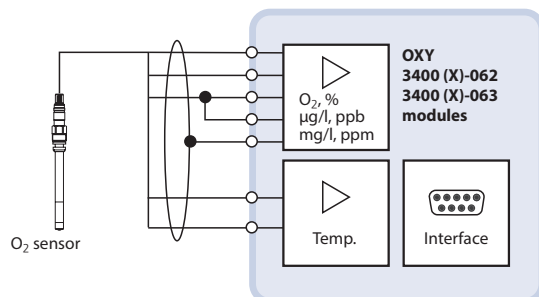
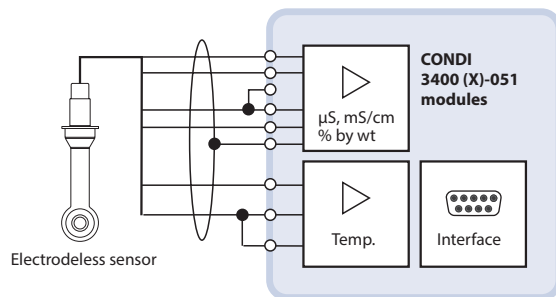
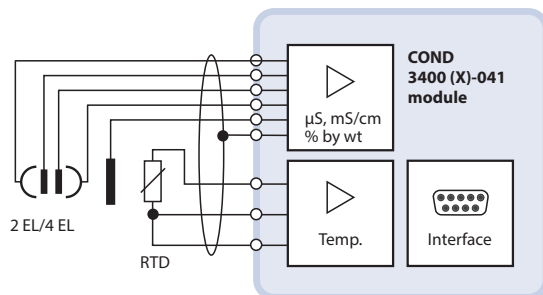
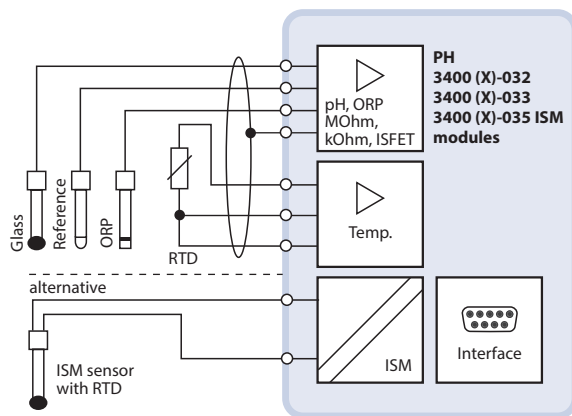

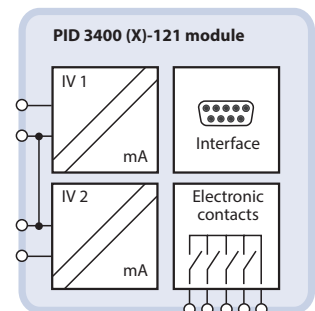
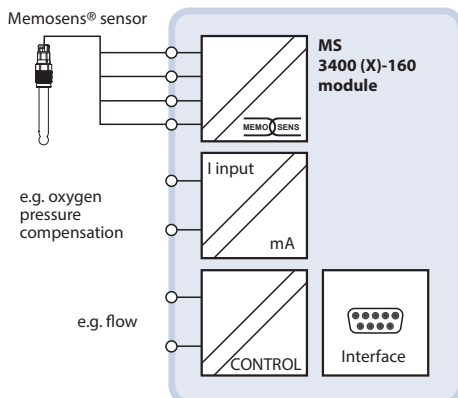
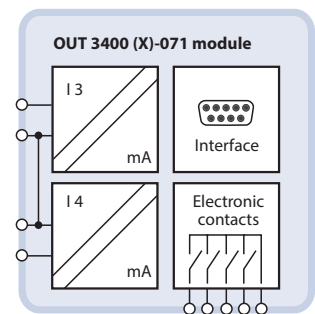
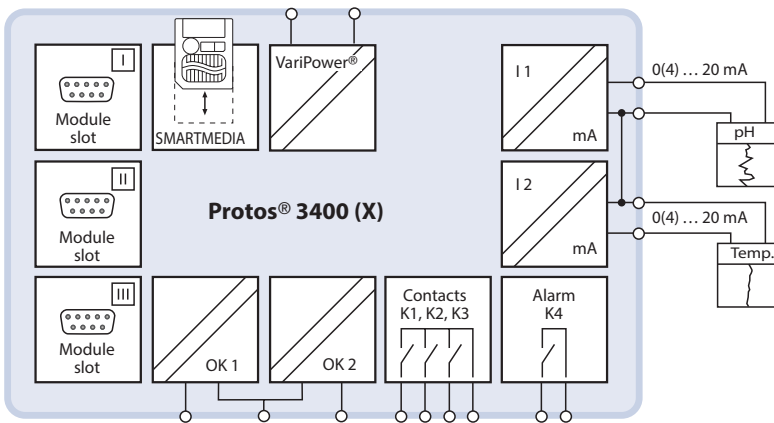
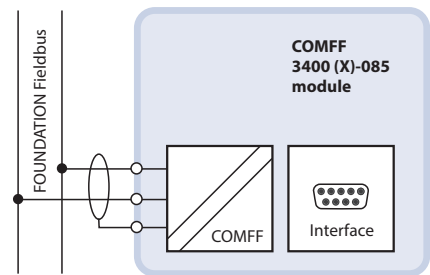
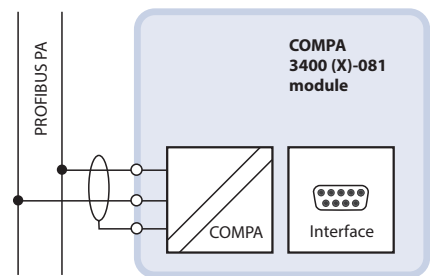
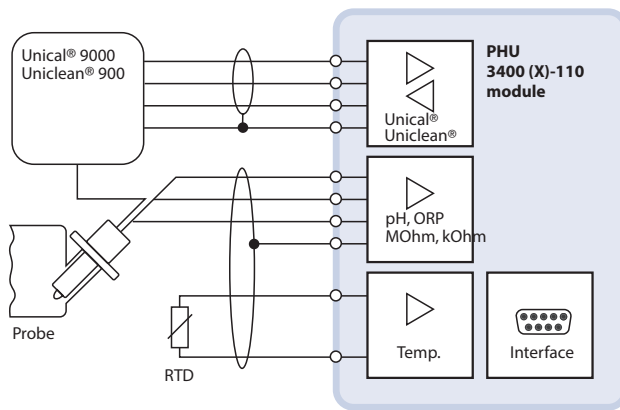

# Process Analysis Systems

Chem

Energy

Pharm

Food

Water

## Protos® 3400 (X)

### Menu Structure

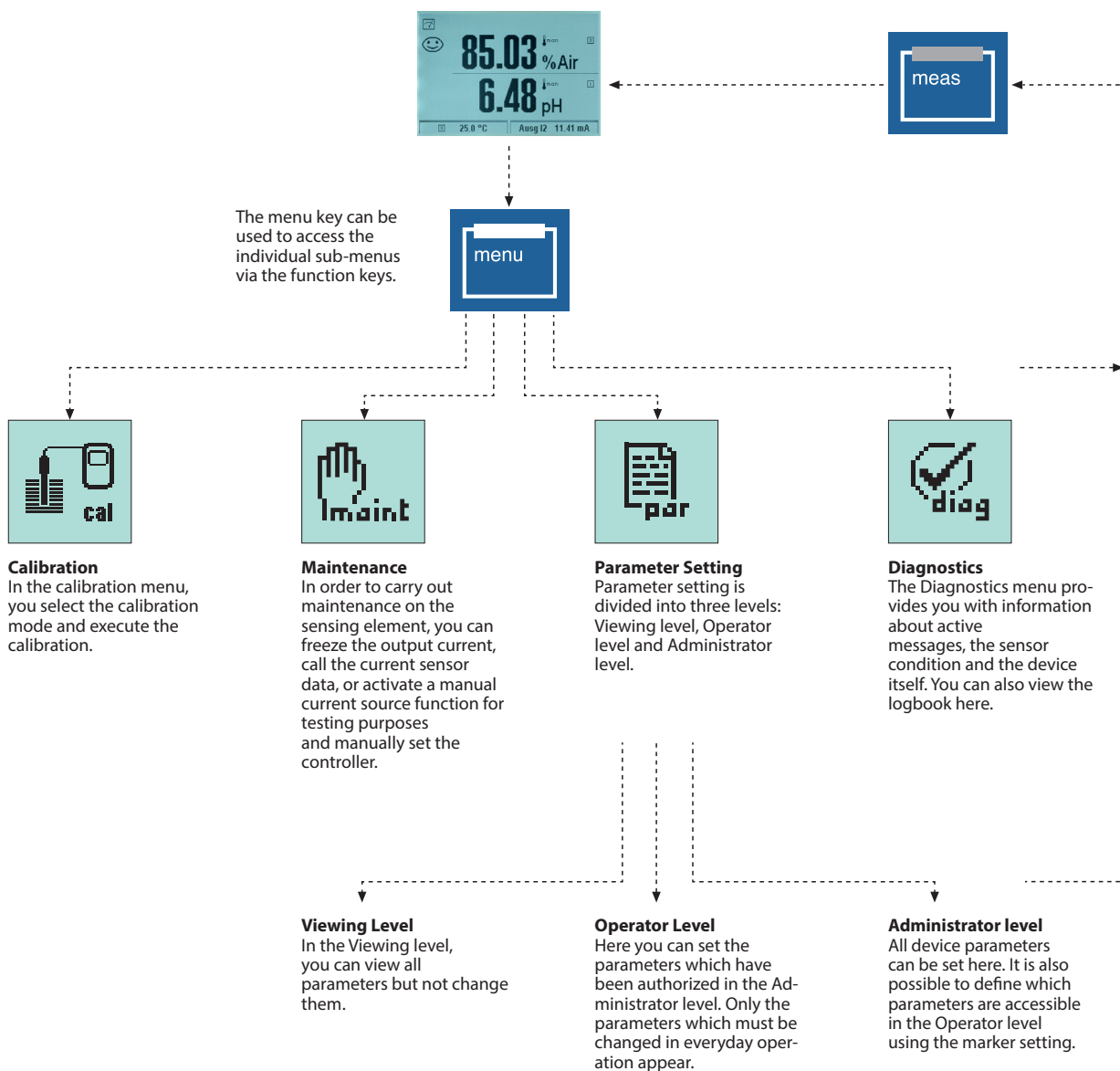



### Innovative Display

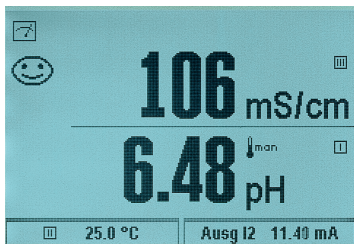

Measurement display with two primary values (above) and two secondary displays (below), i.e. 4 measured values can be simultaneously represented on the display.



Clear icon menu; selected icon blinks black/gray.

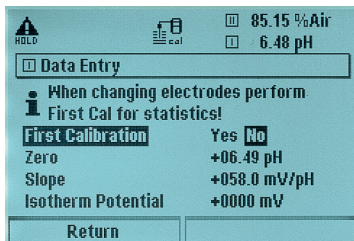

Example of a message box, e.g. with safety information.

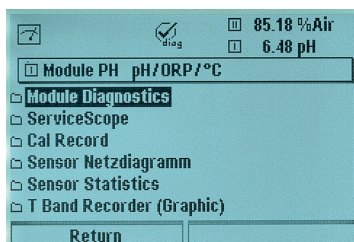

Menu logic based on MS Windows with scroll bar.

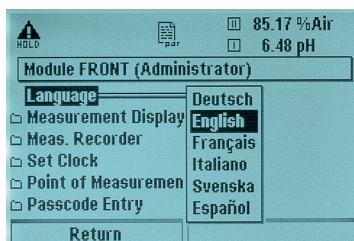

Selection of a configuration via pull-down menus.



- transfective LC graphic display (240 x 160 pixels); high resolution and contrast-rich; with half-tone visualization
- optimal legibility even in the most difficult light conditions thanks to white backlighting
- plain-text user interface according to NAMUR – simple and intuitive
- menu texts can be switched to: German, English, French, Italian, Spanish, and Swedish
- menu logic based on Windows standards
- 2 softkeys with context-dependent functionality

# Process Analysis Systems

Chem

Energy

Pharm

Food

Water

## Protos® 3400 (X)

### Product Line Protos® 3400

Device		Order No.
Protos® 3400 S	basic unit/polished stainless steel enclosure VariPower® 20 ... 265 V AC/DC power supply	<b>3400 S</b>
Protos® 3400 C	basic unit/coated steel enclosure VariPower® 20 ... 265 V AC/DC power supply	<b>3400 C</b>
<b>Measuring modules</b>		
PH 3400-032 measuring module	pH module	<b>PH 3400-032</b>
PH 3400-033 measuring module	pH module (double high-resistance)	<b>PH 3400-033</b>
PH 3400-035 measuring module	pH module (ISM)	<b>PH 3400-035</b>
COND 3400-041 meas. module	conductivity module	<b>COND 3400-041</b>
CONDI 3400-051 meas. module	electrodeless conductivity module	<b>CONDI 3400-051</b>
OXY 3400-062 meas. module	oxygen module (standard applications)	<b>OXY 3400-062</b>
OXY 3400-063 meas. module	oxygen module (trace measurements)	<b>OXY 3400-063</b>
OXY 3400-065 meas. module	oxygen module (standard applications/ISM)	<b>OXY 3400-065</b>
OXY 3400-066 meas. module	oxygen module (trace measurements/ISM)	<b>OXY 3400-066</b>
OXY 3400-067 meas. module	oxygen module (trace measurements/increased resolution/ISM)	<b>OXY 3400-067</b>
PHU 3400-110 meas. module	Unical® 9000/Uniclean® 900 communication module	<b>PHU 3400-110</b>
FIU 3400-141 digital module	Memosens®, Unical®, Uniclean®, ComFu® module	<b>FIU 3400-141</b>
MS 3400-160 digital module	Memosens® module	<b>MS 3400-160</b>
<b>Communication modules</b>		
OUT 3400-071 output module	output expansion module	<b>OUT 3400-071</b>
PID 3400-121 controller module	PID controller module	<b>PID 3400-121</b>
COMPA 3400-081 PROFIBUS PA module	PROFIBUS PA module	<b>COMPA 3400-081</b>
COMFF 3400-085 FOUNDATION Fieldbus module	FOUNDATION Fieldbus module	<b>COMFF 3400-085</b>
<b>Software</b>		
ProgaLog 3000	configuration and documentation software	<b>SW 3000</b>

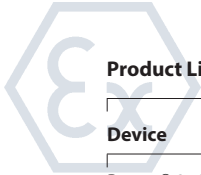

**Product Line Protos® 3400 X**

**Device**

Protos® 3400 X S/VPW

basic unit/polished stainless steel enclosure  
VariPower® 85 ... 253 V AC power supply

Order No.

**3400 X S / VPW**

Protos® 3400 X S/24 V

basic unit/polished stainless steel enclosure  
24 V AC/DC power supply

**3400 X S / 24V**

Protos® 3400 X C/VPW

basic unit/coated steel enclosure  
VariPower® 85 ... 253 V AC power supply

**3400 X C / VPW**

Protos® 3400 X C/24 V

basic unit/coated steel enclosure  
24 V AC/DC power supply

**3400 X C / 24V**

**Measuring modules**

PH 3400 X-032 meas. module

pH module

**PH 3400X-032**

PH 3400 X-033 meas. module

pH module (double high-resistance)

**PH 3400X-033**

PH 3400 X-035 meas. module

pH module (ISM)

**PH 3400X-035**

COND 3400 X-041 meas. module

conductivity module

**COND 3400X-041**

CONDI 3400X-051 meas. module

electrodeless conductivity module

**CONDI 3400X-051**

OXY 3400 X-062 meas. module

oxygen module (standard applications)

**OXY 3400X-062**

OXY 3400 X-063 meas. module

oxygen module (trace measurements)

**OXY 3400X-063**

OXY 3400 X-065 meas. module

oxygen module (standard applications/ISM)

**OXY 3400X-065**

OXY 3400 X-066 meas. module

oxygen module (trace measurements/ISM)

**OXY 3400X-066**

OXY 3400 X-067 meas. module

oxygen module (trace measurements/increased resolution/ISM)

**OXY 3400X-067**

PHU 3400 X-110 module

Unical® 9000 X/Uniclean® 900 X communication module

**PHU 3400X-110**

FIU 3400X-140 digital module

Memosens®, Unical®, Uniclean® module

**FIU 3400X-140**

MS 3400X-160 digital module

Memosens® module

**MS 3400X-160**

**Communication modules**

OUT 3400X-071  
output module

output expansion module

**OUT 3400X-071**

PID 3400X-121 contr. module

PID controller module

**PID 3400X-121**

COMPA 3400X-081  
PROFIBUS PA module

PROFIBUS PA module

**COMPA 3400X-081**

COMFF 3400X-085  
FOUNDATION Fieldbus module

FOUNDATION Fieldbus module

**COMFF 3400X-085**

**Software**

ProgaLog 3000

configuration and documentation software

**SW 3000**

# Process Analysis Systems

Chem

Energy

Pharm

Food

Water

## Protos® 3400 (X)

### Product Line Protos® 3400 (X)

Accessories		Order No.
Pipe-mount kit		ZU 0544
Panel-mount kit		ZU 0545
Protective hood		ZU 0548
Adapter M20 x 1.5 to NPT 1/2"		ZU 0658
Connector plugs and cables		
VP8 connector plug		ZU 0721
M12 device socket		ZU 0822
VP8-ST cable (both ends with VP socket)	length: 3 m	ZU 0710
	length: 5 m	ZU 0711
	length: 10 m	ZU 0712
Memory expansion		
SMARTMEDIA card (128 MB)		ZU 0543-128
AuditTrail card (replacement)		ZU 0599
Additional functions (SMARTMEDIA card included)		
5 loadable parameter sets		SW 3400-102
Measurement recorder		SW 3400-103
Extended logbook		SW 3400-104
Software update		SW 3400-106
Software downgrade		on request
Electronic data recording and backup according to FDA 21 CFR Part 11		SW 3400-107
Additional functions (SMARTMEDIA card not required)		
KI recorder (pH)		SW 3400-001
Buffer sets, specifiable (pH)		SW 3400-002
ServiceScope® (pH)		SW 3400-004
Tolerance band recorder (pH)		SW 3400-005
Current characteristic definable		SW 3400-006
TC ultrapure water (Cond)		SW 3400-008
Concentration determination (Cond, CondI)		SW 3400-009
Dissolved-oxygen measurement in carbonated beverages (e.g. beer)		SW 3400-011
ISFET functionality for pH 3400 (X)-035 measuring module		SW 3400-012
2nd Memosens® channel		SW 3400-014
Oxygen measurement with FIU 3400-141, FIU 3400 X-140, MS 3400 (X)-160 modules		SW 3400-015
Trace-oxygen measurement with FIU 3400-141, FIU 3400 X-140, MS 3400 (X)-160 modules		SW 3400-016



Product Line – continued

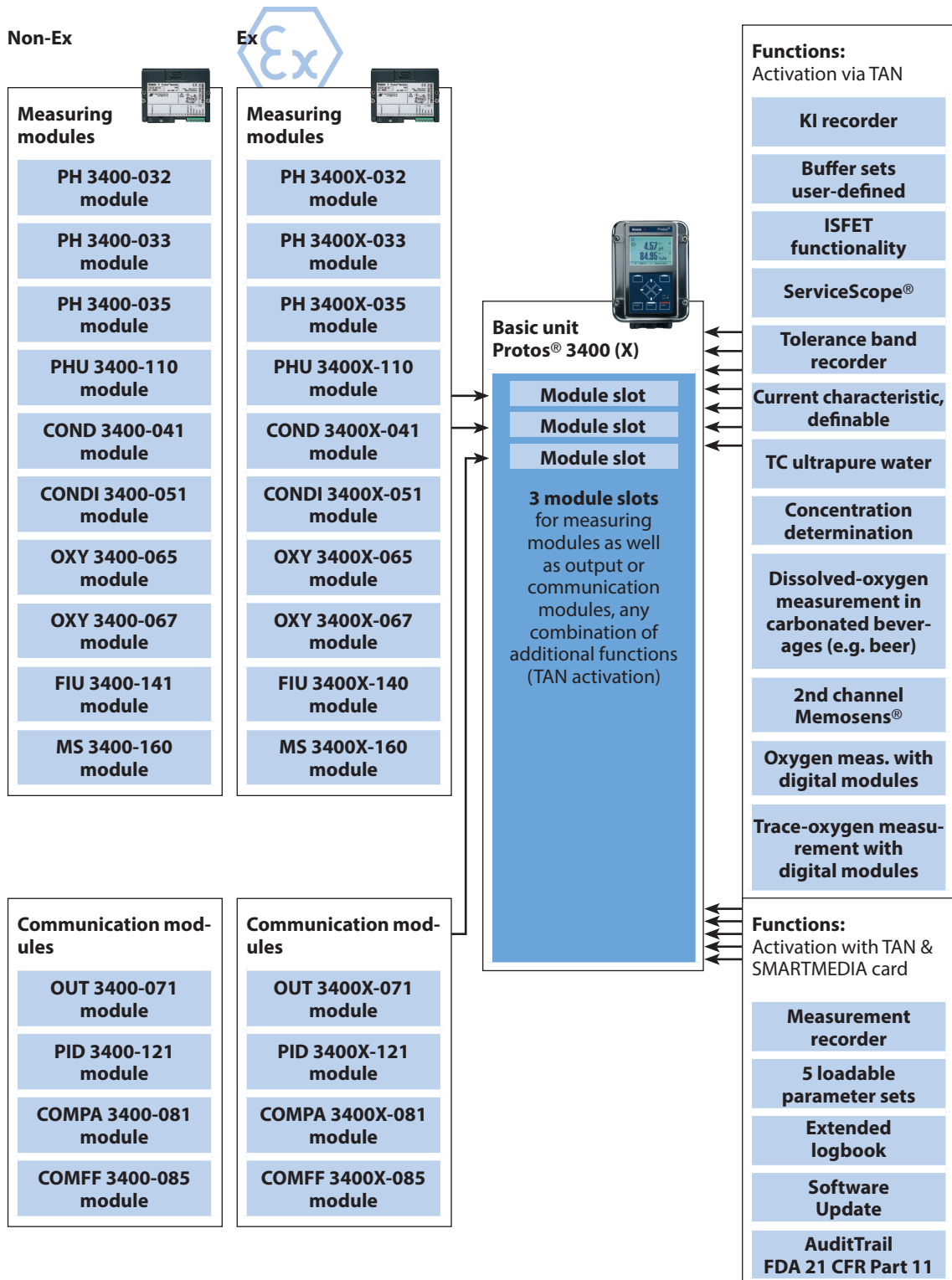



# Process Analysis Systems

Chem

Energy

Pharm

Food

Water

## Protos® 3400 (X)

### Device Equipment

<input checked="" type="checkbox"/> Device status	<input type="checkbox"/> Buffer sets specifiable	<input checked="" type="checkbox"/> Activation of SMARTMEDIA card slot
<input checked="" type="checkbox"/> 2 parameter sets	<input checked="" type="checkbox"/> Adaptive calibration timer	<input type="checkbox"/> 5 loadable parameter sets
<input checked="" type="checkbox"/> ORP measurement (SHE)	<input checked="" type="checkbox"/> USP function (Cond)	<input type="checkbox"/> Measurement recorder
<input checked="" type="checkbox"/> Sensor network diagram	<input type="checkbox"/> ServiceScope®	<input type="checkbox"/> Extended logbook
<input checked="" type="checkbox"/> Calimatic®	<input type="checkbox"/> Tolerance band recorder	<input type="checkbox"/> Software update
<input checked="" type="checkbox"/> Sensocheck®	<input type="checkbox"/> Current characteristic definable	<input type="checkbox"/> Dissolved-oxygen measurement in carbonated beverages (e.g. beer)
<input checked="" type="checkbox"/> VariPower® power supply	<input checked="" type="checkbox"/> TC ultrapure water (pH)	<input type="checkbox"/> ISFET functionality
<input checked="" type="checkbox"/> 2 current outputs	<input type="checkbox"/> TC ultrapure water (Cond)	<input type="checkbox"/> "Electronic Records" and "Electronic Signatures" according to directive FDA 21 CFR, Part 11
<input checked="" type="checkbox"/> 4 relay contacts	<input type="checkbox"/> Concentration determination	<input type="checkbox"/> Oxygen measurement with digital modules
<input type="checkbox"/> KI recorder		<input type="checkbox"/> Trace-oxygen measurement with digital modules

The functions marked with ● are already installed in the device as standard.

The functions marked with ○ can either be retrofitted by TAN (Trans Action Number) or are available via SMARTMEDIA card in connection with a TAN (see product line, page 348).



### Specifications Protos® 3400 (X) S and Protos® 3400 (X) C

Display	LC graphic display, white backlighting	
Resolution	240 x 160 pixels	
Languages	German, English, French, Italian, Spanish, Swedish (Portuguese)	
Keypad	NAMUR keypad, individual keys, no double assignments [meas] [menu] [▼] [▲] [▶] [◀] [enter] [softkey 1] [softkey 2], NAMUR-LEDs red and green	
Logbook	recording of function activations, appearance and disappearance of warning and failure messages, with date and time	
Storage capacity	approx. 50 entries without SMARTMEDIA card, can be read from display and exported via SMARTMEDIA card	
Extended logbook	> 50000 entries, depending on capacity of SMARTMEDIA card	
Measurement recorder	2-channel measurement recorder with marking of events (failure, maintenance request, function check, limit values)	
Recording medium	SMARTMEDIA card	
Recording capacity	> 50000 entries, depending on capacity of SMARTMEDIA card	
Recording	process variables and span selectable	
Recording method	snapshot, min/max. or mean value	
Time base	10 s ... 10 h/pixel	
Zoom function	tenfold zoom in the event of high rate of change	
Sensor monitor	direct display of measured values from sensor for validation	
KI recorder	adaptive representation of process flow with monitoring and signaling of critical process parameters	
Device self-test	testing of RAM, FLASH, EEPROM, display and keypad, records for QM documentation in accordance with ISO 9000	
Clock	real-time clock with date	
Power reserve	approx. 1 year (lithium battery)	
Data retention in case of power failure	parameters and factory settings	> 10 years (EEPROM)
	logbook, statistics, records	> 1 year (lithium battery)
	measurement recorder	SMARTMEDIA card
Module slots	3	
Power supply	24 (-15 %) ... 230 (+15 %) V AC/DC	approx. 10 VA/10 W
Overvoltage category	II	
Protection class	I	
Pollution degree	2 (EN 61010-1)	
Wire cross-section	2.5 mm <sup>2</sup>	

# Process Analysis Systems

Chem

Energy

Pharm

Food

Water

## Protos® 3400 (X)

### Specifications Protos® 3400 (X) S and Protos® 3400 (X) C – continued

Protection against electric shock	protective separation of all low-voltage circuits from mains to EN 61010
Input OK 1	galvanically separated (OPTO coupler)
Function	switches the device to HOLD mode (function check)
Switching voltage	0 ... 2 V AC/DC inactive      10 ... 30 V AC/DC active
Input OK 2	galvanically separated (OPTO coupler)
Function	START/STOP KI recorder, switchover to second parameter set
Switching voltage	0 ... 2 V AC/DC inactive      10 ... 30 V AC/DC active
Current output I 1	0/4 ... 20 mA (22 mA), max. 10 V, galvanically separated (galv. connected to output I 2)
Load monitoring	error message if load is exceeded
Overrange*)	22 mA in the case of a message
Measurement error <sup>1)</sup>	< 0.2 % current value      + 0.02 mA
Current source	0.00 ... 22.00 mA
Current output I 2	0/4 ... 20 mA (22 mA), max. 10 V, galvanically separated (galv. connected to output I 1)
Load monitoring	error message if load is exceeded
Overrange*)	22 mA in the case of a message
Measurement error <sup>1)</sup>	< 0.2 % current value      + 0.02 mA
Current source	0.00 ... 22.00 mA
Switching contacts*)	4 relay contacts K1 ... K4, floating/K1, K2, K3 are connected on one side
Loadability	AC < 30 V/< 3 A, 90 VA      DC < 30 V/< 3 A, 90 W
Usage*)	K1 ... K3, user definable as NAMUR maintenance request/function check, limit values, parameter set 2 active, rinsing contact, USP contact, K4 permanently set as alarm contact (NAMUR failure)
EMC	NAMUR NE 21 and EN 61326
Emitted interference	Class B
Immunity to interference	industry
Lightning protection	EN 61000-4-5, Installation Class 2
Nominal operating conditions	ambient temperature -20 ... +55 °C, relative humidity 10 ... 95 %, not condensing power supply 24 (-15 %) ... 230 (+15 %) V AC/DC, frequency AC 45 ... 65 Hz
Transport/Storage temperature	-20 ... +70 °C

For up-to-date information, please visit [www.knick.de](http://www.knick.de)

Isolation Amplifiers  
Transmitters

Indicators

Process Analytics

Portable Meters

Laboratory Meters

Sensors

Fittings

**Knick** 

### Specifications Protos® 3400 (X) S and Protos® 3400 (X) C – continued

Enclosure	Protos® S: stainless steel, polished, 1.4305 Protos® C: coated stainless steel
Assembly	wall mounting/pipe mounting/panel mounting, sealed against panel
Dimensions	see dimension drawings from page 358
Protection	IP 65/NEMA 4 X
Cable glands	5 M20 x 1.5 cable glands
Weight	approx. 3.2 kg plus approx. 150 g per module

<sup>\*)</sup> user-defined

<sup>1)</sup> according to IEC 746 Part 1, at nominal operating conditions

# Process Analysis Systems

Chem

Energy

Pharm

Food

Water

## Protos® 3400 (X)

### Specifications Protos® 3400 (X) S and Protos® 3400 (X) C – continued

#### Explosion protection

IECEX:	Ex me ib [ia] IIC T4/Ex tD A21 IP54 T 70 °C
ATEX:	II 2(1) G Ex me ib [ia] IIC T4/II 2 D Ex tD A21 IP54 T 70 °C
FM:	NI, Class I, Div 2, GRP A, B, C, D, T4, NIFW with AIS connections to Class I, II, III, Div 1, GRP A-G, Entity Class I, Zone 1, A Ex me ib [ia] IIC, T4, Entity Class I, Zone 2, A Ex nA IIC, T4, NIFW
CSA:	NI, Class I, Div 2, GRP A, B, C, D, with IS circuits extending into Div 1 AIS, Class I, Zone 1, Ex me ib [ia] IIC T4, Enclosure 4X NI, Class I, Zone 2, Ex nA [ia] IIC, Enclosure 4X
GOST:	2 Ex me ib [ia] IIC T4, applications – explosive zones 1 and 2, indoor and outdoor
NEPSI:	Ex mb ib [ia] IIC T4/DIP A21 T <sub>A</sub> , T6

#### Nominal operating conditions

ambient temperature -20 ... +50 °C, relative humidity 10 ... 95 %, not condensing

#### Power supply (Ex em IIC)

VPW: 100 (-15 %) ... 230 (+10 %) V AC < 15 VA, 48 ... 62 Hz  
or  
24 V: AC 24 V (-15 %, +10 %) < 15 VA, 48 ... 62 Hz  
DC 24 V (-15 %, +20 %) < 8 W

#### Overvoltage category

II

#### Protection class

I

#### Pollution degree

2 (EN 61010-1)

#### Wire cross-section

2.5 mm<sup>2</sup>

#### Ground wire connection

2.5 mm<sup>2</sup>, screw M4 (EN 61010-1, 6. 5.1.2.)

#### Protection against electric shock

protective separation of all low-voltage circuits (SELV) from mains by double insulation to EN 61010-1

#### Input OK 1 (Ex ib IIC)

galvanically isolated (OPTO coupler), galvanic isolation up to 60 V, protective separation through double insulation to EN 61010-1

#### Function

switches the device to HOLD mode (function check)

#### Switching voltage

inactive 0 ... 2 V AC/DC  
active 10 ... 30 V AC/DC  
Ex ib IIC U<sub>i</sub> = 30 V

#### Input OK 2 (Ex ib IIC)

galvanically isolated (OPTO coupler)  
galvanic isolation up to 60 V  
protective separation through double insulation to EN 61010-1

#### Function

START/STOP KI recorder, switchover to second parameter set

#### Switching voltage

inactive 0 ... 2 V AC/DC  
active 10 ... 30 V AC/DC  
Ex ib IIC U<sub>i</sub> = 30 V

#### Current output I 1 (Ex ib IIC)

0/4... 20 mA (22 mA), max. 10 V,  
galvanically isolated (galvanically connected with output I 2)  
galvanic isolation up to 60 V  
protective separation due to double insulation to EN 61010-1  
Ex ib IIC U<sub>o</sub> = 17 V  
I<sub>o</sub> = 84 mA  
P<sub>o</sub> = 357 mW

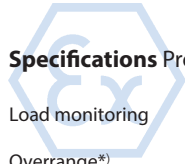

**Specifications** Protos® 3400 (X) S and Protos® 3400 (X) C – continued

Load monitoring	error message if load is exceeded
Overrange <sup>*)</sup>	22 mA in the case of a message
Measurement error <sup>1)</sup>	< 0.2 % current value + 0.02 mA
Current source	0.00 ... 22.00 mA
Current output I 2 (Ex ib IIC)	0/4... 20 mA (22 mA), max. 10 V, galvanically isolated (galvanically connected with output I 1) galvanic isolation up to 60 V protective separation due to double insulation to EN 61010-1 Ex ib IIC $U_o = 17\text{ V}$ $I_o = 84\text{ mA}$ $P_o = 357\text{ mW}$
Load monitoring	error message if load is exceeded
Overrange <sup>*)</sup>	22 mA in the case of a message
Measurement error <sup>1)</sup>	< 0.2 % current value + 0.02 mA
Current source	0.00 ... 22.00 mA
Relay contacts <sup>*)</sup> (Ex ib IIC)	4 relay contacts K1 ... K4 , floating/K1, K2, K3 connected on one side galvanic isolation to 60 V protective separation due to double insulation to EN 61010-1 Ex ib IIC $U_i = 30\text{ V}$ $I_i = 500\text{ mA}$ $P_i = 10\text{ W}$
Usage <sup>*)</sup>	K1 ... K3, user definable as NAMUR maintenance request/function check, limit values, parameter set 2 active, rinsing contact, USP contact, K4 permanently set as alarm contact (NAMUR failure)

<sup>\*)</sup> user-defined

<sup>1)</sup> according to IEC 746 Part 1, at nominal operating conditions

# Process Analysis Systems

Chem

Energy

Pharm

Food

Water

## Protos® 3400 (X)

### Contact Assignments

Protos® 3400

20 ... 253 V AC

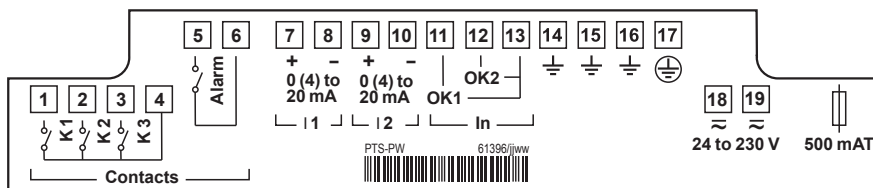

Protos® 3400 X VPW

100 ... 253 V AC

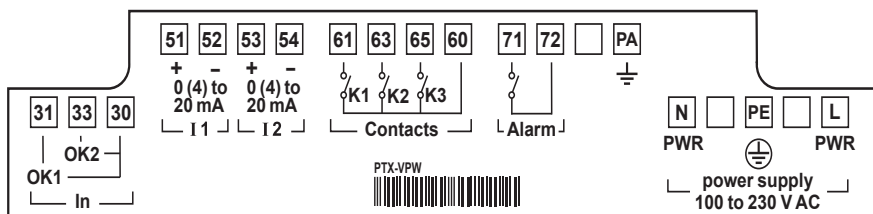

Protos® 3400 X 24 V

24 V AC/DC

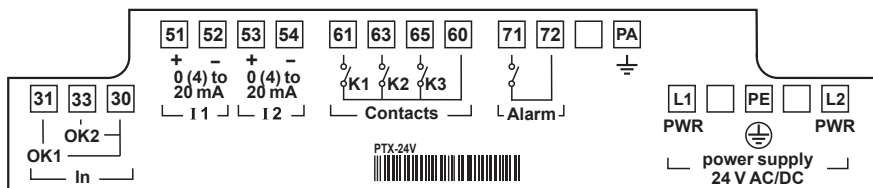

For up-to-date information, please visit [www.knick.de](http://www.knick.de)

**Knick** >

## Mounting Assemblies

### ZU 0544 pipe-mount kit

For assembly on vertical or horizontal pipes or posts.

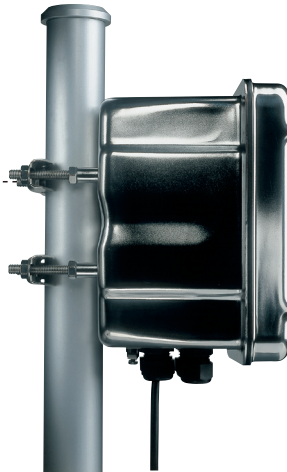

### ZU 0548 protective hood

Additional protection from direct weather exposure and mechanical damage.



### ZU 0545 panel-mount kit

For assembly in standardized panel cutout 144 x 194 mm.





# Process Analysis Systems

Chem

Energy

Pharm

Food

Water

## Protos<sup>®</sup> 3400 (X)

### Dimension Drawings

Front view

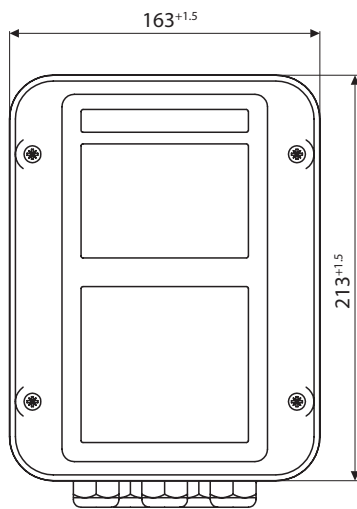

Side view

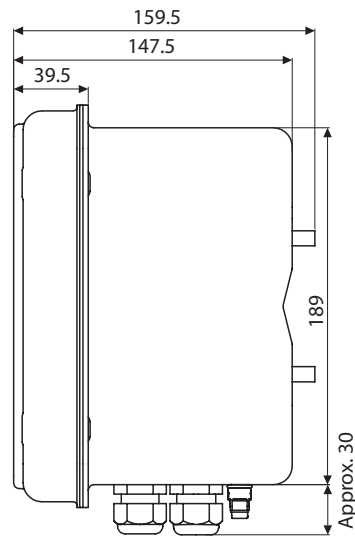

Back view

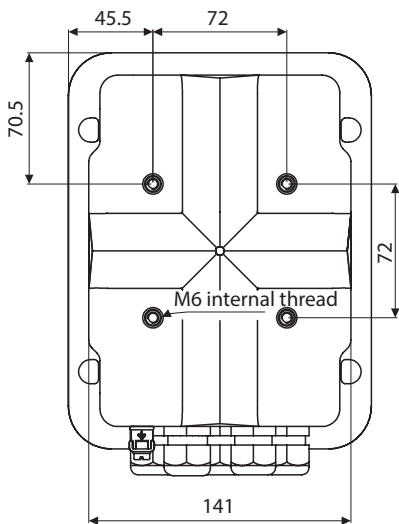

Cable glands  
M20 x 1.5

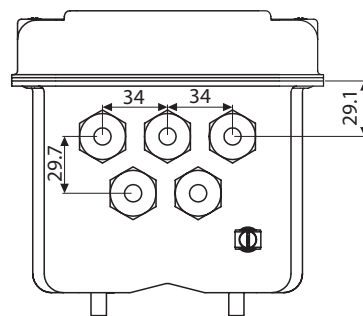

**Dimension Drawings – continued**

**ZU 0544 pipe-mount kit**

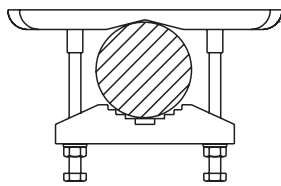
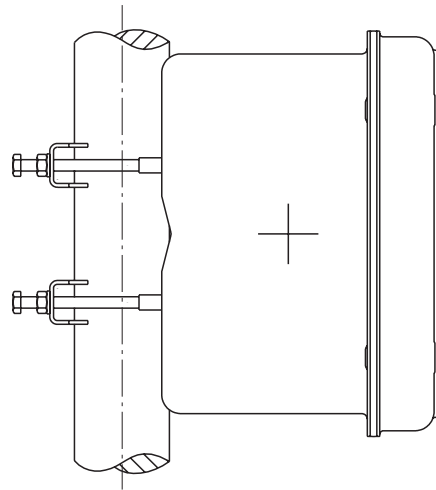
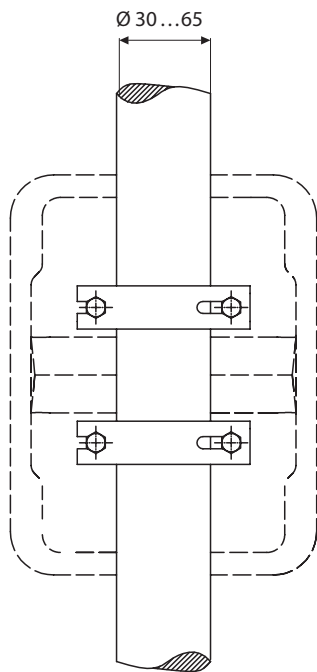

**Wall mounting**

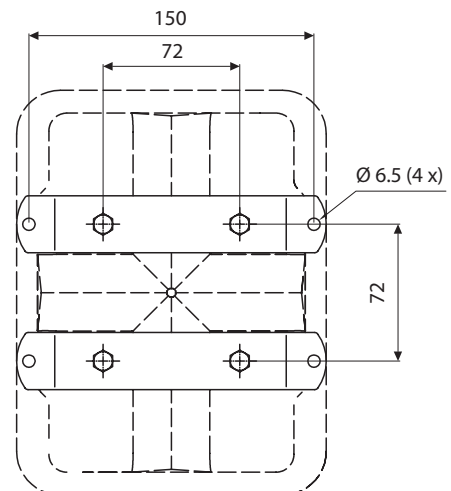

# Process Analysis Systems

Chem

Energy

Pharm

Food

Water

## Protos® 3400 (X)

Dimension Drawings – continued

ZU 0548 protective hood

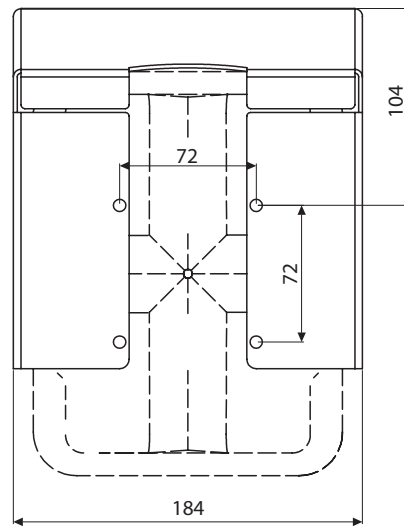
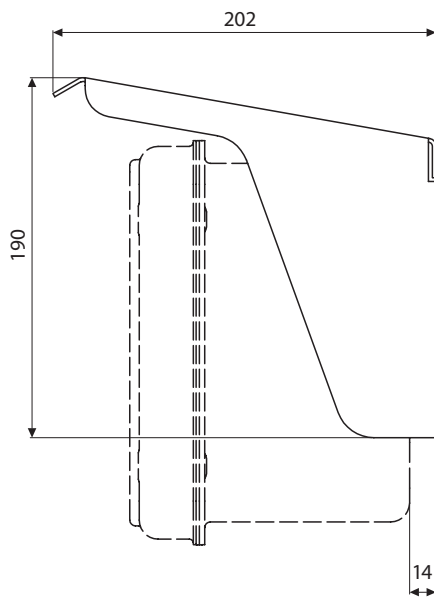

**Dimension Drawings** – continued

**ZU 0545 panel-mount kit**

